

sallén



Sallén Electrum D5

Cash Management
solutions

Sallén Electrum D5

Maximum efficiency
and reliability.



The high-speed range has been designed to adapt to the pace of big companies and provide greater performance and flexibility in all cash deposit transactions.

Today's economy has driven consumers to use less credit and more cash, growing the amount of paper transactions worldwide. Manually managing the flow of currency into business, represents a high cost-low return task, which also carries significant security risks.

Automation offers significant potential for increasing productivity of the entire process.

The Electrum D5 will count, verify and store in a sealed, single use plastic bag inside the safe every banknote deposited. Any tampering of the bag will be evident.

All high speed series adapts to every company's needs in terms of size, capacity and type of storage.

Fast, efficient cash processing

- For businesses dealing with many customers, employees and suppliers every day, the D5 is your best option.
- The capacity and speed of the deposit unit allow you to streamline cash flow, cut on time-consuming operations and ensure a secure environment for your customers and employees.
- Stacked banknotes in bag.
- Multicurrency in the same transaction.
- Multilanguage.
- Sallén One Time Code system to open the safe.
- Visual and tactile interface via colour touch screen.
- Real time accountancy of each transaction.



Different identification
formats



Gain control



Reduce costs



Store safely

Specifications

Model Specifications

Capacity	Up to 2500
Dimension (WxDxH)	410x623x806
Weight Kg	242Kg
800x480 Touch Display	7"
Safe	Grade IV Optional Grade II, UL Type
Manual Deposit	Yes. Anti-fishing slot on the door
Max. Power Specifications	110-240v 50-60 Hz
Storage Type	Thermo sealed bag

Standard features

Deposit Speed	300 banknotes/minute	Remote management	No
Multicurrency deposits	Yes	Remote note reader update	Yes
Multilanguage	Yes	Remote data import & export	Yes
PC	Linux Embedded OS	Time settings	Supports NTP synchronisation
Software Platform	EMA (Easy Modular Assisted)	"Unified POS" standard	Yes
Network	Supports VPN and multi cloud communications	Certifications	CE, ROHS, ECB (banknote reader)
Operating temperature	10o to 40oC	Humidity	5%-95%, non condensating

Options

Bank Note Feeder	250 banknotes capacity	One Time Lock	No
Receipt printer	57mm paper width	Additional locks or ID devices	Please contact Sallén
Barcode Reader	1D Lineal	Application customization	Please contact Sallén

Cash Storage Options

Thermo sealed bag



Dimensions

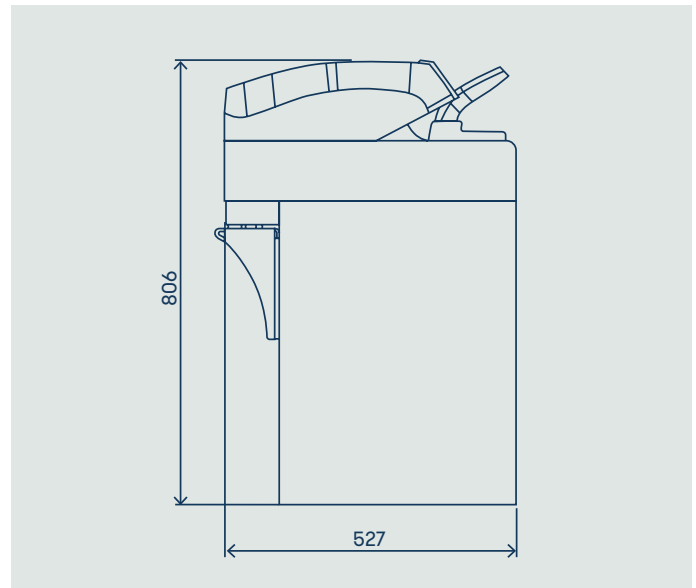

Our goal is to improve the cash cycle in all businesses, every day. So, we believe that by partnering up with all companies that want to make cash management an easy process, we can provide the solution that best meets their needs.

Cash management solutions / Electrum D5 www.sallen.es



A **GUNNEBO**® COMPANY

 **sallén**